

## The SiC structure of the EUCLID NISP instrument

Michel Bougoin<sup>1</sup>, Jérôme Lavenac<sup>1</sup>, Tony Pamplona<sup>2</sup>, Laurent Martin<sup>2</sup>, Jean-Luc Gimenez<sup>2</sup>,  
Didier Castel<sup>3</sup> & Thierry Maciaszek<sup>4</sup>

<sup>1</sup>MERSEN BOOSTEC, France,

<sup>2</sup>Aix Marseille Université, CNRS, LAM, Laboratoire d'Astrophysique de Marseille, UMR7326, France

<sup>3</sup>AIRBUS DEFENCE & SPACE, France,

<sup>4</sup>CNES, France

### I. INTRODUCTION

Euclid is a part of the European Space Agency Cosmic Vision program. Euclid mission's goal is to understand the origin of the accelerating expansion of the Universe. This space mission will embark a 1.2 m Korsch telescope, a visible imager (VIS) and a near-infrared spectrometer and photometer (NISP). The hardware of all of them will be mainly made of Boostec<sup>®</sup> SiC material.

The NISP instrument includes i) a corrector lens (NI-CoLA), ii) a mechanism dedicated to the selection of filters (NI-FWA), iii) a mechanism dedicated to the selection of grisms (NI-GWA), iv) a three lenses camera optics (NI-CaLA), v) a focal plane with mosaic of 16 (2k x 2k) infrared detectors and associated proximity electronics (NI-DS), vi) a calibration unit (NI-CU), vii) an electronic for the data acquisition and processing (NI-DPU) and viii) an electronic for the instrument control and interface with the satellite (NI-ICU).

All these optical, mechanisms and focal plane sub-systems are held by a mechanical structure which must allow i) high dimensional stability, mainly under temperature change (down to 130 K; 100 K for the detectors), ii) high stiffness, iii) high mechanical strength, compatible with the launch stresses and also with the temperature changes, iv) low mass and v) high positioning accuracy and geometry of optical sub-systems. These are the reasons why this structure is based on Boostec<sup>®</sup> SiC technology.

The STM model which has already been successfully manufactured and tested is presented; it is a glued assembly of quite large and complex SiC parts and invar inserts; it includes a main structure called NI-SA-ST and another structure called P4, holding the focal plane, to be bolted on NI-SA-ST.

The NI-SA-ST is made of two SiC panels (P1 and P3) linked together by 6 SiC-bar trusses and also another SiC panel (P2) to be bolted on P1, thus closing the large circular SiC box surrounding the filter and grism wheels.

### II. BOOSTEC<sup>®</sup> SiC MATERIAL FOR SPACE OPTICS

MERSEN BOOSTEC manufactures a **sintered silicon carbide** which is named **Boostec<sup>®</sup> SiC**. Its key properties are a high specific stiffness (420 GPa / 3.15 g.cm<sup>-3</sup>) combined with a high thermal stability (180 W.m<sup>-1</sup>.K<sup>-1</sup> / 2.2 . 10<sup>-6</sup> K<sup>-1</sup>).

Its high mechanical strength allows making structural parts, such as Euclid NISP one.

Thanks to its isotropic microstructure, the physical properties of this alpha type SiC are perfectly isotropic and reproducible inside a same large part or from batch to batch. In particular, no CTE mismatch has been measurable, with accuracy in the range of 10<sup>-9</sup> K<sup>-1</sup> [1]. The CTE of Boostec<sup>®</sup> SiC is decreasing from 2.2 . 10<sup>-6</sup> K<sup>-1</sup> @ room temperature down to 0.2 . 10<sup>-6</sup> K<sup>-1</sup> @ 100 K and close to zero between 0 and 35 K. Its thermal conductivity remains over 150 W/m.K in the 70 K - 360 K temperature range.

This material shows no mechanical fatigue, no outgassing and no moisture absorption nor release. It has been fully qualified for space application at cryogenic temperature such as NIRSpec instrument which will be operated at only 30 K [2].

Structural parts made of Boostec<sup>®</sup> SiC can be easily joined together by brazing (SiC to SiC only), by bolting or by epoxy gluing.

TABLE I. BASIC PROPERTIES OF BOOSTEC<sup>®</sup> SiC

Properties	Typical Values @ 293 K
Density	3.15 g.cm <sup>-3</sup>
Young's modulus	420 GPa
Bending strength / Weibull modulus (coaxial double ring bending test)	400 MPa / 11
Poisson's ratio	0.17
Toughness (K <sub>IC</sub> )	4.0 MPa.m <sup>1/2</sup>
Coefficient of Thermal Expansion (CTE)	2.2 . 10 <sup>-6</sup> K <sup>-1</sup>
Thermal Conductivity	180 W.m <sup>-1</sup> .K <sup>-1</sup>
Electrical conductivity	10 <sup>5</sup> Ω.m

### III. NISP

#### A. EUCLID mission

Euclid is an ESA medium class astronomy and astrophysics space mission, to be launched in 2020.

The Euclid mission aims at understanding why the expansion of the Universe is accelerating and what is the nature of the source responsible for this acceleration which physicists refer to as dark energy. Dark energy represents around 75% of the energy content of the Universe today, and together with dark matter it dominates the Universe's matter-energy content. Both are mysterious and of unknown nature but control the past, present and future evolution of Universe.

THALES Alenia Space will be in charge of the construction of the satellite and its Service Module while AIRBUS Defence & Space will provide the Payload Module. The mirrors and the structures of all the PLM instruments will be mainly made of Boostec® SiC material, giving required lightweight, stiffness, strength and dimensional stability.

Euclid will embark a 1.2 m Korsch telescope feeding 2 instruments, VIS and NISP: a high quality panoramic visible imager (VIS), a near infrared 3-filter photometer (NISP-P) and a spectrograph (NISP-S). With these instruments physicists will probe the expansion history of the Universe and the evolution of cosmic structures by measuring the modification of shapes of galaxies induced by gravitational lensing effects of dark matter and the 3-dimension distribution of structures from spectroscopic red-shifts of galaxies and clusters of galaxies, with a look-back time of 10 billion years.

The satellite will orbit at L2 Sun-Earth Lagrangian Point for a 6 years mission.

#### B. NISP instrument

NISP (Near Infrared Photo-Spectrometer) is one of the two instruments to be fed by the large Euclid telescope. It will operate in the near infrared spectral region (0.9 – 2  $\mu$ m). This instrument will be cooled down in order to operate at 130 K and even 100 K for its detectors. NISP will fit within a volume of 1.2 m x 0.65 m x 0.65 m and weigh around 90 kg.

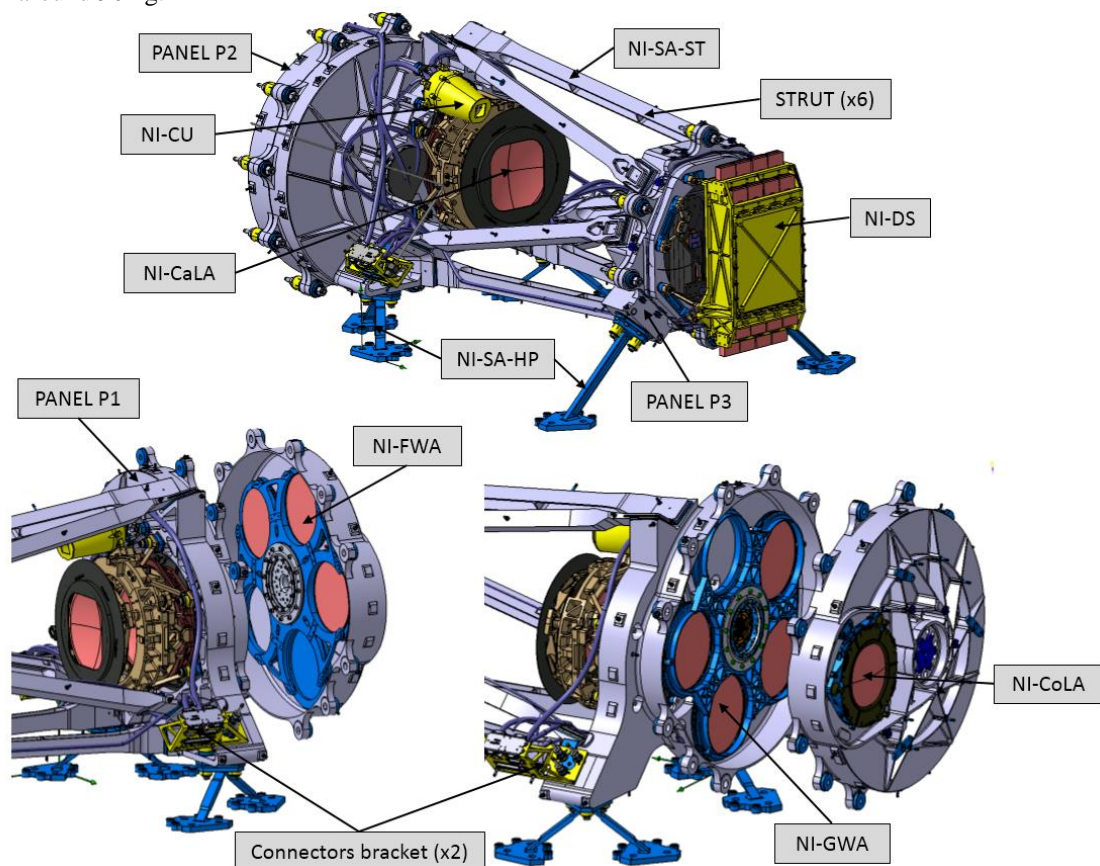

Fig. 1. Overview of NISP instrument

The NISP instrument includes six main optomechanical modules, to be mounted on a common structure, i) a corrector lens (NI-CoLA), ii) a mechanism dedicated to the selection of filters (NI-FWA), iii) a mechanism dedicated to the selection of grisms (NI-GWA), iv) a three lenses camera optics (NI-CaLA), v) a focal plane with mosaic of 16 (2k x 2k) infrared detectors and associated proximity electronics (NI-DS), vi) a calibration unit (NI-CU), vii) an electronic for the data acquisition and processing (NI-DPU) and viii) an electronic for the instrument control and interface with the satellite (NI-ICU) [3] [4].

The NISP assembly will be mounted directly on the large SiC telescope with help of Invar® kinematic mounts.

In the Euclid Consortium, LAM (LABORATOIRE d'ASTROPHYSIQUE DE MARSEILLE) is responsible for the development of the main structure of the NISP instrument called NI-SA and also NI-DS, the structure which holds the focal plane.

### C. NISP Structure Assembly (NI-SA)

The main functions of the NI-SA are i) to integrate, position and maintain the different optomechanical sub-systems, ii) to resist to the different environmental conditions encountered during the NISP whole life and iii) to maintain the optical concept performances during the NISP whole life.

The NI-SA has been designed by LAM with AIRBUS Defence & Space expertise; the main drivers were as following: i) mass < 95 kg, ii) stiffness, 1<sup>st</sup> mode > 80 Hz, iii) mechanical strength, iv) optical stability (only a few tens of microns allowed), v) static design loads of 5.5 g in plane combined with 9.5 g out of plane, vi) sine vibrations loads between 10 and 12.1 g at low frequencies, vii) low but critical random vibration loads due to the size of the instrument and the low damping of the structure [3].

After a trade-off, the Boostec® SiC material has been selected for NI-SA as it ensures a very high dimensional stability and mechanical strength through temperature changes. Its high mechanical strength and its high stiffness are compatible with the launch stresses [3]. It has also been selected for same reasons for the P4 panel, the interface of the NI-FPA (focal plane) system with NI-SA; the P4 panel is bolted to the NI-SA P3 panel [4].

## IV. DESCRIPTION OF THE NISP STRUCTURE ASSEMBLY (NI-SA)

The main structure is made of two SiC panels, P1 and P3 linked together with six SiC struts which are glued on the SiC panels according to Fig. 2. The so obtained hexapod ensures a very high stiffness of the structure and a dimensional stability between the reference optomechanical assembly and the focal plane.

The third SiC panel (P2), the secondary structure, is bolted on the P1 panel with 11 M8 bolts the tensile pre-load of which is close to 2.5 tons, thus requiring very good interface flatness. The P2 panel also closes the large circular SiC box surrounding the filter and grism wheels.

The NI-SA SiC structure holds 44 kg while its own weight is only 40 kg. Its overall size is 1 m x 0.65 m x 0.65 m. P1 and P3 panels are quite large, with complex geometry and then challenging SiC parts as they have to match with all sub-assemblies interfaces.

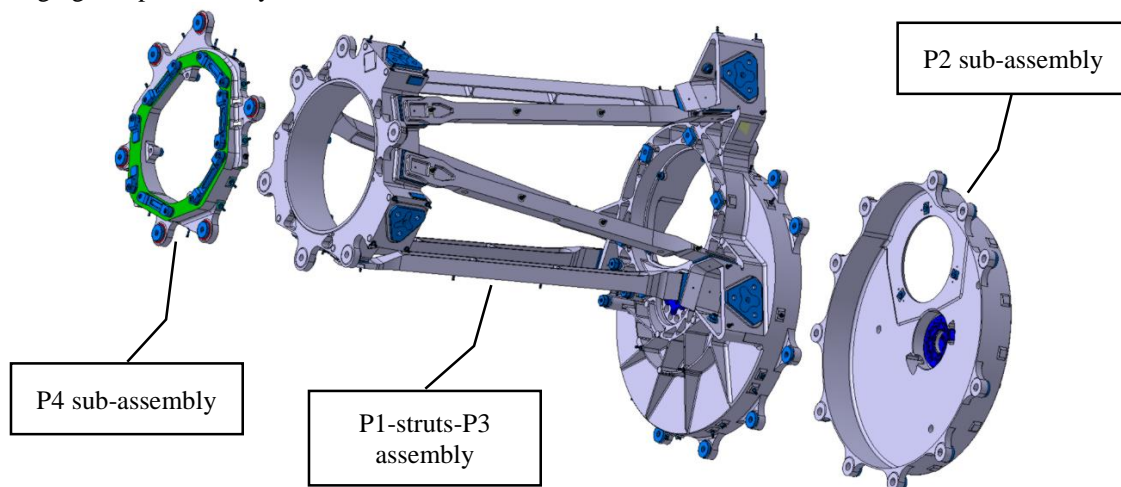

Fig. 2. Overview of NISP STM SiC parts

All sub-systems are mounted on the SiC panel through bonded Invar<sup>®</sup> pads. M93 Invar<sup>®</sup> has been selected thanks to its low Coefficient of Thermal Expansion (CTE) matching very well with the one of Boostec<sup>®</sup> SiC and its perfect stability at cryogenic temperature. These pad are glued on SiC with a space qualified adhesive. For bolting purpose, Helicoil<sup>®</sup> screw thread inserts are mounted in the Invar<sup>®</sup> pads.

Invar<sup>®</sup> pads are also bonded as thrust washers for the M8 bolts (on P1, P2 and P4 panels), MLI studs and laser tracker ball holders.

## V. Boostec<sup>®</sup> SiC MANUFACTURING TECHNOLOGY FOR NISP STRUCTURE

### A. Manufacturing monolithic SiC parts

All NISP SiC parts have been manufactured with the standard process for monolithic SiC parts which has been successfully operated in MERSEN BOOSTEC since more than 15 years. Commonly, monolithic SiC parts of up to 1.7 m x 1.2 m x 0.6 m (or  $\Phi 1.25$  m) are manufactured. The flight models are obtained with the sequence of steps detailed in Fig. 3. The SiC Premix is a mixture of fine SiC powder with dedicated sintering additives and temporary binders. It is shaped into big blocks (> 1 ton each) by isostatic pressing. The parts are then machined (high speed machining) very close to the final shape at the green stage i.e. when the material is still very soft, similar to chalk.

These shaped parts are then sintered by heating-up to around 2100°C under a protective atmosphere, thus transforming the compacted powder blank into a hard and stiff ceramic material. The even “as-sintered” surfaces look highly smooth, with a typical Ra roughness of only 0.4  $\mu\text{m}$ ; they can be used as is, without any sand blasting or any other rework. The interfaces of the structural parts are then ground and possibly lapped in order to obtain accurate shape (down to 1  $\mu\text{m}$  flatness) and location.

The parts are checked crack-free with help of UV fluorescent dye penetrant. They are measured with a large size accurate CMM.

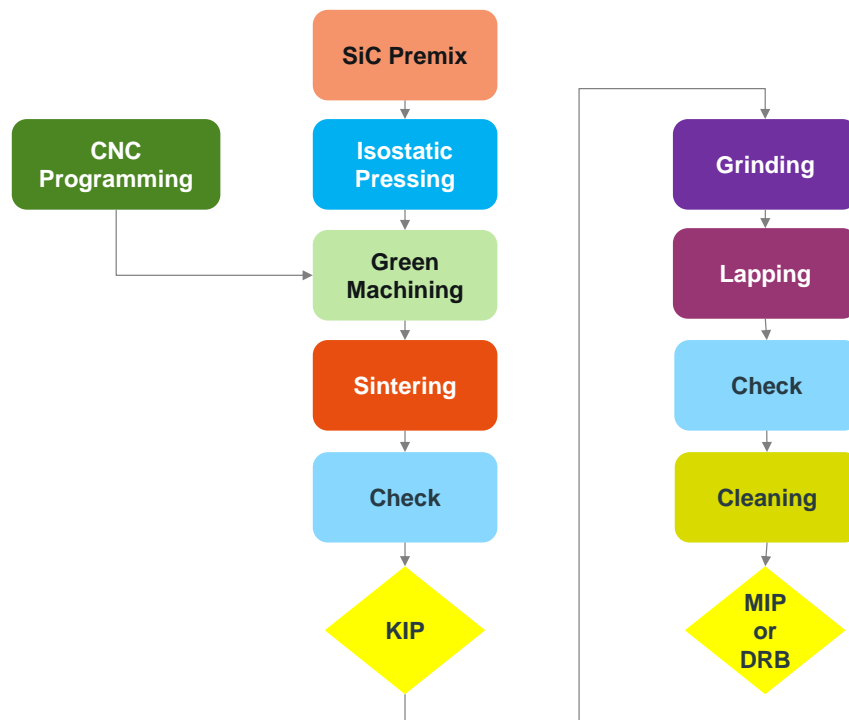

Fig. 3. Manufacturing process for monolithic sintered SiC parts

All SiC parts are fully checked (measurements, material quality) after sintering, in the frame of KIP (Key Inspection Point), before engaging next steps.

All SiC parts are again fully checked (measurements, material quality) at the end of their manufacturing process, in the frame of MIP (Mandatory Inspection Point), thus giving authorization for next gluing step. It is a DRB (Delivery Review Board) in case the SiC part is delivered as is, without any further gluing step.



### *B. Manufacturing metallic pads*

The M93 Invar<sup>®</sup> material of the metallic pads is submitted to a dedicated heat treatment before machining, following the supplier recommendation. Because of the tight dimensional and geometrical tolerances, milling these pads is also a technical challenge.

The screw thread inserts are mounted in the machined pads afterwards, when required.

### *C. Glued Assembly*

Strong SiC/SiC and SiC/Invar<sup>®</sup> bonds are obtained from the same space qualified structural adhesive; this is an epoxy based two part adhesive, designed for use where toughness and high strength are required. Prior to bonding, both metallic and SiC surfaces must be carefully prepared for purpose of hydrocarbon contaminants and oxide removal [5]. The adhesive can be introduced by two methods: i) coating the surface to be glued or ii) injection. The joint thickness is calibrated in order to obtain optimal strength. The bonded assemblies are cured according to the adhesive supplier recommendations.

Specific tools are designed and implemented by MERSEN BOOSTEC in order to hold the parts during the assembly and to reach the specified tolerances. In a first step, the invar<sup>®</sup> pads mechanical interfaces must be located accurately in the reference frame of their attached SiC part; then the main P3 panel interface must be located very accurately in the NI-SA reference frame which is attached to the P1 panel: 100  $\mu\text{m}$  parallelism, 200  $\mu\text{m}$  concentricity and +/- 100  $\mu\text{m}$  "focus" length.

The quite complex sequence of assembly steps of the main structure (P1-struts-P3) is described in Fig. 6. We proceed in three steps: i) pre-assembly of invar pads on each SiC part, ii) assembly of the former pre-assemblies all together (Fig.5) and then iii) bonding non-structural pads. Each pre-assembly is fully checked and reviewed through a Mandatory Inspection Point giving authorization to proceed with further bonding.

P2 and P4 SiC-Invar<sup>®</sup> assemblies are obtained from same sequence of steps as P1 pre-assembly.



**Fig. 4.** Detailed view of P1 SiC panel ready for assembly **Fig. 5.** CMM check of the main structure assembly

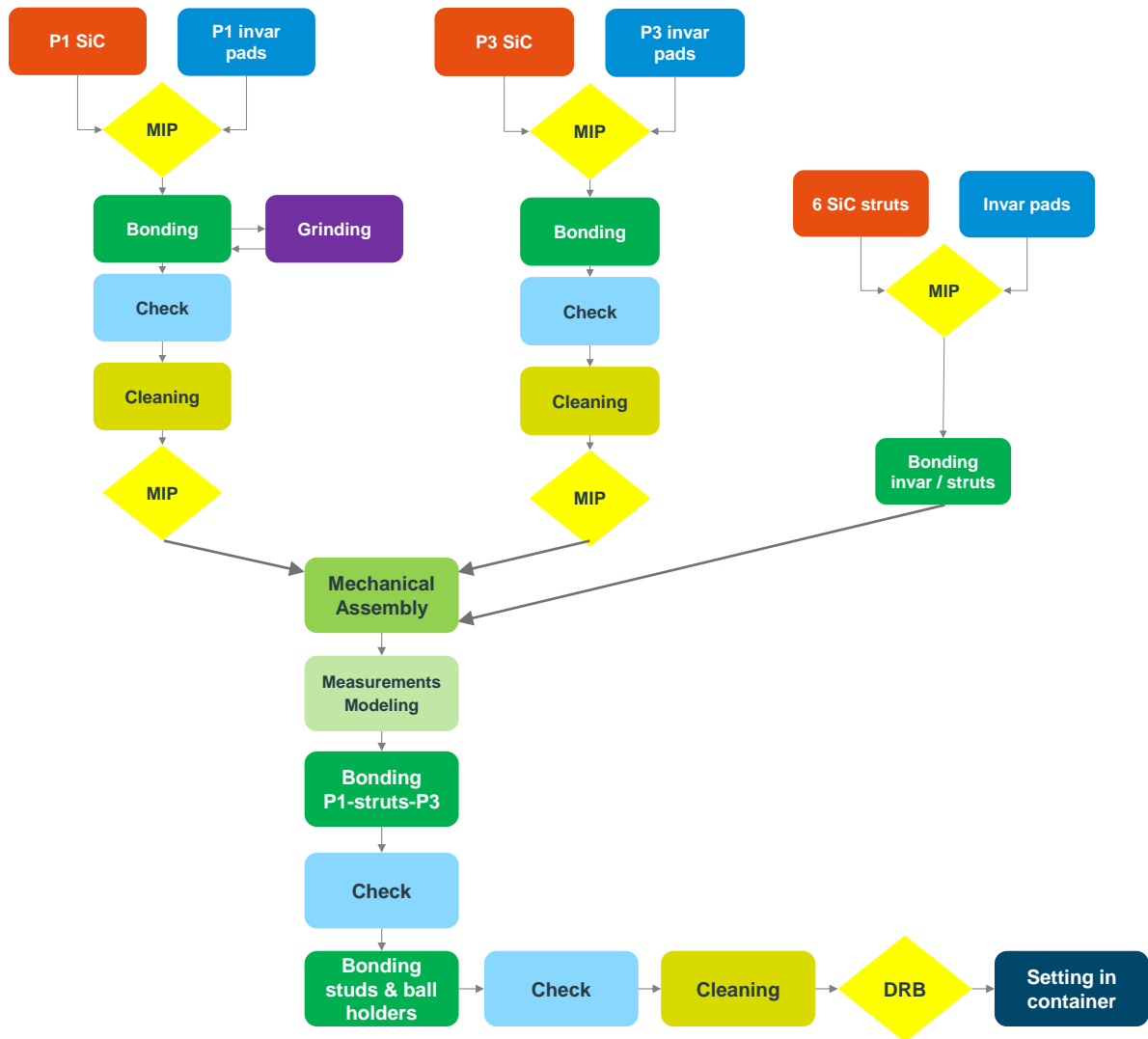

Fig. 6. Assembly process of NI-SA main structure

## VI. NISP STM

The design of the structure of the NISP Structural and Thermal Model, the first one, has been validated by LAM by building a detailed Finite Element Model [3].

It has been then successfully manufactured by MERSEN BOOSTEC. All gluing assemblies have been successful; in particular the location of P3 interfaces in the NI-SA reference frame (attached to P1 panel) was really better than specified: 75  $\mu\text{m}$  concentricity, 35  $\mu\text{m}$  parallelism and “focus” length error comprised between -21  $\mu\text{m}$  and + 12  $\mu\text{m}$  only.

Three devices have been delivered to LAM from mid-2015 to early 2016: i) the P4 sub-assembly (Fig. 7), ii) the P2 sub-assembly (Fig. 8) and iii) the main structure (P1-struts-P3) assembly (Fig. 9).

All STM optomechanical sub-systems, the focal plane and also the MLI have then been integrated at LAM (Fig.10).

Sine and random vibration tests have been defined by LAM in order to qualify the instrument under Euclid satellite launch vibration environment. The so defined tests have been successfully performed at CSL (Centre Spatial de Liège, Belgium) by mid-2016, on the fully integrated STM thus validating LAM design, MERSEN BOOSTEC manufacturing and assembling work and also LAM integration [3]. Furthermore, the behaviour of the STM specimen during these vibration tests correlated very well with the LAM predictions from Finite Elements Analysis, thus consolidating the predicted margins.



**Fig. 7.** STM P4 panel sub-assembly



**Fig. 8.** STM P2 panel sub-assembly



**Fig. 9.** STM main structure assembly at DRB

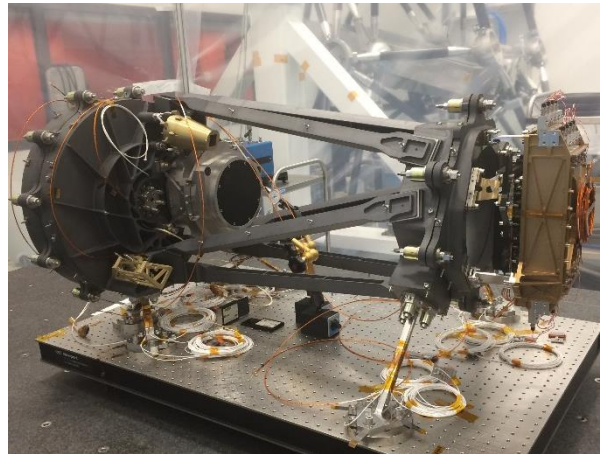

**Fig. 10.** STM integrated at LAM (without MLI)

## VII. NISP STATUS AND PERSPECTIVES

Following the STM vibration tests, thermal balance and thermal cycling tests have been implemented recently without any damage of the bolted and the glued junctions. The structure will be measured again with a CMM in order to check the structure stability during the last tests. The STM will be delivered to AIRBUS Defence & Space in September 2016.

Taking profit of the lessons learnt through the successful STM campaign, the Proto Flight Model (PFM) has been designed by LAM with only minor changes from the STM. The manufacturing of the relevant PFM SiC parts is just starting. The NISP PFM will be mounted on the Euclid FM telescope.

### VIII. CONCLUSION

In the frame of ESA Euclid project, with AIRBUS Defence & Space expertise, LAM and MERSEN BOOSTEC, have developed the SiC structure of the NISP instrument. This concept allows to obtain the required high level of strength and dimensional stability at Euclid environment condition.

A first Structural and Thermal Model has been successfully designed, manufactured, integrated and tested. The manufacturing activities of the following Proto Flight Model are now starting; it'll be mounted on the large Euclid SiC telescope to be launched in 2020.

The present work confirms the ability of MERSEN BOOSTEC to manufacture large and complex SiC parts at space standard but also to make large, accurate and highly stable glued assemblies made of Boostec® SiC parts and Invar® pads.

### REFERENCES

- [1] M. Bougoin, D. Castel, F. Levallois, "CTE homogeneity, isotropy and reproducibility in large parts made of sintered SiC", *Proceedings of ICSO 2012 (International Conference on Space Optics)*, Ajaccio, France, Oct. 9-12, 2012
- [2] K. Honnen, A. Kommer, B. Messerschmidt, T. Wiehe, "NIRSpec OA development process of SiC components", *Advanced Optical and Mechanical Technologies in Telescopes and Instrumentation*. Edited by Atad-Etchedgui, Eli; Lemke, Dietrich. *Proceedings of the SPIE*, Volume 7018, 2008.
- [3] T. Pamplona, J-L. Gimenez, A. Febvre, W. Ceria, L. Martin, E. Prieto, T. Maciaszek, B.Foulon, F. Ducret, M. Bougoin, D. Castel, « Silicon carbide main structure for Euclid NISP instrument in final development », *Proceedings of the SPIE, Advances in Optical and Mechanical Technologies for Telescopes and Instrumentation II*, Volume 9912, 2016
- [4] A. Bonnefoi, W. Bon, M. Niclas, B.G.B. Sohlein, O. Torvanger, R. Schistad, B.Foulon, J. Garcia, S. Vives, « Focal plane mechanical design of the NISP/Euclid instrument », *Proceedings of the SPIE, Space Telescopes and Instrumentation 2016: optical, infrared and millimeter wave*, Volume 9904, 2016.
- [5] F. Levallois, PhD thesis, « Collage structural du carbure de silicium », Institut National Polytechnique de Toulouse, 1995